

**Determination of installed thermal resistance into a roof and into a wall of
ATI COMBI PRO LIN according to EN ISO 6946:2017**

(test name)

Test method: Determination of installed thermal resistance into a roof and into a wall according to EN ISO 6946:2017
(number of normative document or test method, description of test procedure, test uncertainty)

Product name: ATI COMBI PRO LIN
(identification of the specimen)

Customer: SAS ATI FRANCE, 146 Avenue du Bicentenaire – FR-01 120 Dagneux, France
(name and address of enterprise)

Manufacturer: SAS ATI FRANCE, 146 Avenue du Bicentenaire – FR-01 120 Dagneux, France

Calculation results:

Roof slope angle, α	Calculation method reference no.	Calculation result, R , ($\text{m}^2 \cdot \text{K} / \text{W}$)
Flat roof ($\alpha = 0^\circ$)	EN ISO 6946:2017	7.01
Pitched roof ($\alpha = 30^\circ$)		7.11
Pitched roof ($\alpha = 45^\circ$)		7.17
Wall ($\alpha = 90^\circ$)		7.40

R value for others pitched sloop (different α value) can be determined by linear interpolation between two calculated R values

Calculation

made by: Building Physics Laboratory, Institute of Architecture and Construction of Kaunas University of Technology
(Name of the organization)

Products used in calculation: Ventilated air layer (external surface resistance R_{se}).
Multilayer reflective insulation product **ATI PRO LIN-3** (test report no. 138 SF/23 U).
Emissivity of ATI PRO LIN-3 upper surface $\varepsilon = 0.85^*$; lower surface $\varepsilon = 0.15^*$;
Unventilated air layer 20 mm;
Multilayer reflective insulation product **ATI PRO PREMIUM** (test report no. 106 SF/23 U). Emissivity of ATI PRO PREMIUM upper surface $\varepsilon = 0.10^*$; lower surface $\varepsilon = 0.10^*$;
Unventilated air layer 20 mm.
* Declared by the manufacturer

Additional information: Application, 2023-09-20

Annex: Annex 1. Calculation results

(the numbers of the annexes should be pointed out)

Head of Laboratory:

(approves the test results)

K. Banionis

(n., surname)

(signature)

Calculated by

(calculation made by)

J. Ramanauskas

(n., surname)

(signature)

Validity – the named data and results refer exclusively to the tested and described specimens.

Notes on publication – no part of this document may be photocopied, reproduced or translated to another language without the prior written consent of the Building Physics Laboratory.

Annex 1: Calculation results

Table 1: Products R- values

Product	Thermal resistance R, (m ² ·K)/W
ATI PRO LIN-3 (test report n° 138 SF/23 U)	R_{core90/90} = 2.54
ATI PRO PREMIUM (test report n°. 106 SF/23 U)	R_{core90/90} = 3.52

*"R_{core90/90}" is the declared R core value following EN 16012 + A1.
"R_{core90/90}" is calculated on 4 results of 4 samples came from 4 different fabrication dates following EN 16012 + A1 (and using the fractile 90/90 calculation rules $S_{R-prod} = \sqrt{\frac{\sum(R_i - R_{average})^2}{n-1}}$);*

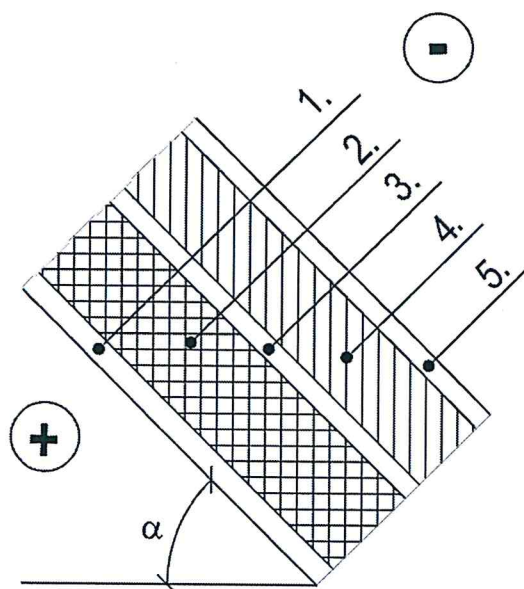

Temperature regime 20°C / 0°C	
1.	Unventilated Air cavity #1, 20 mm
2.	ATI PRO PREMIUM
3.	Unventilated Air cavity #2, 20 mm
4.	ATI PRO LIN-3
5.	Ventilated Air cavity #3, 20 mm

Figure 1. Roof construction design

Table 2: Roof construction calculation results for slope $\alpha = 0^\circ$ (EN ISO 6946)

ATI COMBI PRO LIN installed on roof			
Angle: $\alpha = 0^\circ$	Layer	R value	Unit
Ascendant Heat Flux (Winter period)	Unventilated Air cavity # 1	0.3983	m ² ·K/W
	ATI PRO PREMIUM	3.52	m ² ·K/W
	Unventilated Air cavity # 2	0.4402	m ² ·K/W
	ATI PRO LIN-3	2.54	m ² ·K/W
	Ventilated Air cavity # 3 (the thermal resistance of external surface R_{se})	0.1119	m ² ·K/W
	R_{Total}	7.01	m²·K/W

Validity – the named data and results refer exclusively to the tested and described specimens.
Notes on publication – no part of this document may be photocopied, reproduced or translated to another language without the prior written consent of the Building Physics Laboratory.

Table 3: Roof construction calculation results for slope $\alpha = 30^\circ$ (EN ISO 6946)

ATI COMBI PRO LIN installed on roof			
Angle: $\alpha = 30^\circ$	Layer	R value	Unit
Ascendant Heat Flux (Winter period)	Unventilated Air cavity # 1	0.4391	m ² ·K/W
	ATI PRO PREMIUM	3.52	m ² ·K/W
	Unventilated Air cavity # 2	0.4905	m ² ·K/W
	ATI PRO LIN-3	2.54	m ² ·K/W
	Ventilated Air cavity # 3 (the thermal resistance of external surface R_{se})	0.1229	m ² ·K/W
	R_{Total}	7.11	m²·K/W

Table 2: Roof construction calculation results for slope $\alpha = 45^\circ$ (EN ISO 6946)

ATI COMBI PRO LIN installed on roof			
Angle: $\alpha = 45^\circ$	Layer	R value	Unit
Ascendant Heat Flux (Winter period)	Unventilated Air cavity # 1	0.4628	m ² ·K/W
	ATI PRO PREMIUM	3.52	m ² ·K/W
	Unventilated Air cavity # 2	0.5203	m ² ·K/W
	ATI PRO LIN-3	2.54	m ² ·K/W
	Ventilated Air cavity # 3 (the thermal resistance of external surface R_{se})	0.1293	m ² ·K/W
	R_{Total}	7.17	m²·K/W

Table 3: Wall construction calculation results for slope $\alpha = 90^\circ$ (EN ISO 6946)

ATI COMBI PRO LIN installed on wall			
Angle: $\alpha = 90^\circ$	Layer	R value	Unit
Ascendant Heat Flux (Winter period)	Unventilated Air cavity # 1	0.5522	m ² ·K/W
	ATI PRO PREMIUM	3.52	m ² ·K/W
	Unventilated Air cavity # 2	0.6362	m ² ·K/W
	ATI PRO LIN-3	2.54	m ² ·K/W
	Ventilated Air cavity # 3 (the thermal resistance of external surface R_{se})	0.1554	m ² ·K/W
	R_{Total}	7.40	m²·K/W

Requirements for calculation validity:

- Calculations of R values are valid for a pitched roof (α is generally from 0° to 90°).
- Calculations of R values are valid when ATI PRO is installed in agreement with the installation guidelines described into the manufacturer brochure.

Validity – the named data and results refer exclusively to the tested and described specimens.
Notes on publication – no part of this document may be photocopied, reproduced or translated to another language without the prior written consent of the Building Physics Laboratory.